



VORTEX FACTORY: Via E. Fermi, 5 - 27040 Campospinoso (PV) - ITALY - Tel. +39 0385 765200

ROK GP

OWNER'S

MANUAL



VORTEX FACTORY: Via E. Fermi, 5 - 27040 Campospinoso (PV)- ITALY - Tel. +39 0385 765200

TABLE OF CONTENTS

1. GENERAL INFORMATION	
1.1. Introduction	3
1.2. Symbols	3
1.3. Safety information	3
1.4. Technical Specifications	4
1.5. Special Technical Specifications for Homologated Engine	4
1.6. Packaging	4
2. ENGINE ASSEMBLY	5
3. ENGINE ASSEMBLY/CHASSIS	16
4. STARTING AND BREAK-IN	26
5. SERVICING YOUR ENGINE	28
5.1. Maintenance Schedule and Adjustments	28
5.2. Torque Chart	28
5.3. Sizes and Measures	29
5.4. Chain	29
5.5. Throttle Cable	29
5.6. Carburettor	30
5.7. Spark Plug	31
5.8. Exhaust	31
5.9. Clutch and Starter Gear	31
5.10. Pinion	33
5.11. Cylinder Head	34
5.12. Cylinder	34
5.13. Piston	35
5.14. Connecting Rod	37
5.15. Bottom End	37
6. ENGINE EXPLODED VIEW AND PARTS LIST	38
7. CONTACTS	50



VORTEX FACTORY: Via E. Fermi, 5 – 27040 Campospino (PV)– ITALY – Tel. +39 0385 765200

1.1. INTRODUCTION

Thank you for your purchasing of a Vortex engine. This manual contains information on how to help you with getting the best results from your new engine. Furthermore, it will explain you how to operate your Vortex engine safely and in a proper manner.

Vortex update this manual constantly. All the information in this manual is based on the latest experience and product information available at the time of writing. Vortex reserve the right to make any kind of changes to this manual at anytime without notice and without incurring in any obligation.

This manual shall be considered part of the Vortex engine and should remain with the engine itself if resold.

1.2. SYMBOLS



Personal Injury



Mechanical Danger



Caution

Pay attention to the symbols of this manual. They alert you of dangerous situations for you or for your engine.

1.3. SAFETY INFORMATION



- Do not start the engine indoor as garages, trailers etc. Start the engine in a well-ventilated area only. Exhaust emission are hazardous to your health.
- Always wear gloves and proper clothing when working on your engine.
- Use caution when handling fuel. Gasoline is flammable and explosive. When working with fuel, do not smoke or use it near fire or flames. Avoid any skin contact and inhaling fuel vapors.
- Never touch moving parts when the engine is running.
- During operation both engine and muffler become very hot. Do not touch them and do not place anything on them after operation.
- Do not touch the spark plug or cable. It may provoke electrical shocks.
- Understand the operation of all controls and learn how to stop the engine quickly in case of emergency.
- Do not use the engine without clutch cover and chain protection.



VORTEX FACTORY: Via E. Fermi, 5 - 27040 Campospinoso (PV) - ITALY - Tel. +39 0385 765200

TECHNICAL SPECIFICATIONS



Cylinder Displacement (max)	125cc.
Cylinder Bore (max)	54.00 mm.
Pistone Stroke	54.00 mm.
Admission system	Reed Valve in the Crankcase
Cooling System	Liquid
Carburettor	Dell'Orto VSH 30
Ignition System	PVL
Ignition Type	Analogic
Ignition Timing	3 mm.
Spark Plug Gap	0.8 mm.
% Fuel Mixture	4%
Engine Weight (Complete)	19 kg.

- All sizes and measurements in this manual are expressed in metrics.
- Always use original Vortex parts and proper tools when working on your engine.
- Proper fuel mix is necessary for optimum engine life and performance.

1.4. SPECIAL TECHNICAL SPECIFICATIONS FOR HOMOLOGATED ENGINES



Vortex Rok Gp is produced in two versions: "Senior" and "Junior" lowered powered version. However, refer to your country homologation file for eventual specific rules and/or siezes.

1.5. PACKAGING

Your engine will be packed in a sealed box with the Vortex logo printed on and a sticker with model and serial number attached. I twill be a second box complete with accessories as carburettor, muffler, fuel pump, air box, etc.

2. ENGINE ASSEMBLY



In order to perform this job, you will need the following tools:



VORTEX FACTORY: Via E. Fermi, 5 - 27040 Campospinoso (PV)- ITALY - Tel. +39 0385 765200

Compressed air	
Allen T-wrench	3 - 4 - 5 - 6 - 8 mm
Fixed wrench	5 - 7 - 8 - 10 - 13 - 14 - 17 - 22 mm
Flat plier	
Hollowed T-wrench	10 mm
Hook	
Flat bar	
Crosshead Screwdriver	
Plier	
Torque Wrench	

1



Compressed air

Unpack the engine and remove any packaging material on it.

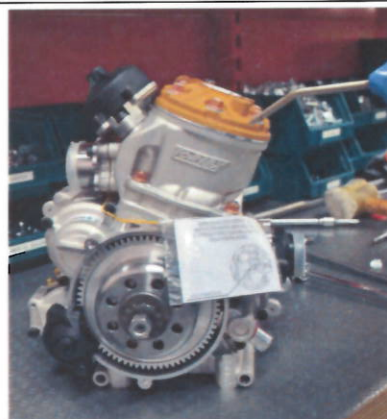

2



6mm Allen T-Wrench

Lay the engine on its side and attach the engine mount to the engine base with four 8mm Allen screws.





VORTEX FACTORY: Via E. Fermi, 5 - 27040 Campospinoso (PV) - ITALY - Tel. +39 0385 765200

3

In case you need to drill your engine plate, we show you the drilling center distances.

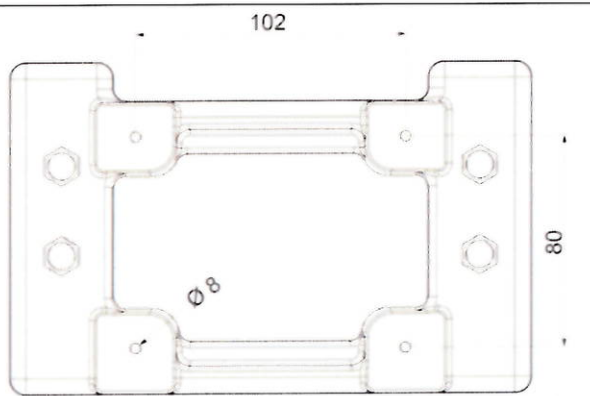

4



22mm Fixed Wrench

Remove the oil filler cap and fill with **30 cc of engine oil, viscosity 40W90**
Replace the oil cap and check that the indicator lamp is fully covered with oil (arrow). If this is not the case, add more engine oil until complete coverage of the indicator lamp.

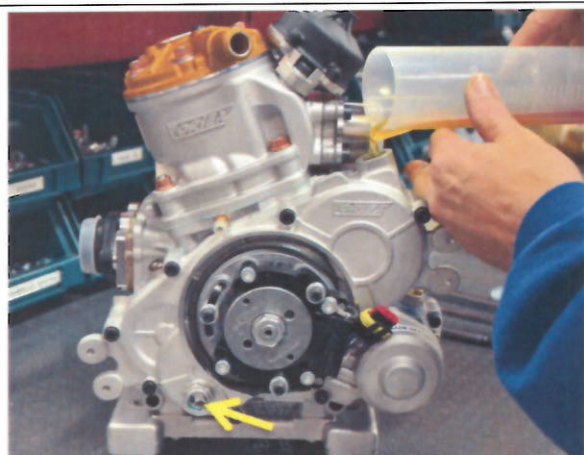

5



10mm Fixed Wrench

Mount the fuel pump chrome-metal support plate to the engine support by means of the 2 pan-head screws supplied (yellow arrow).
Insert the 2 silent blocks (red arrows) in the drilling holes using the 5mm spacers and secure them with the washers and the 6 mm nuts supplied.





VORTEX FACTORY: Via E. Fermi, 5 - 27040 Campospinoso (PV)- ITALY - Tel. +39 0385 765200

6



10mm Fixed Wrench

Mount the fuel pump on the silent blocks. Secure by using the washers and the 6mm nuts supplied.

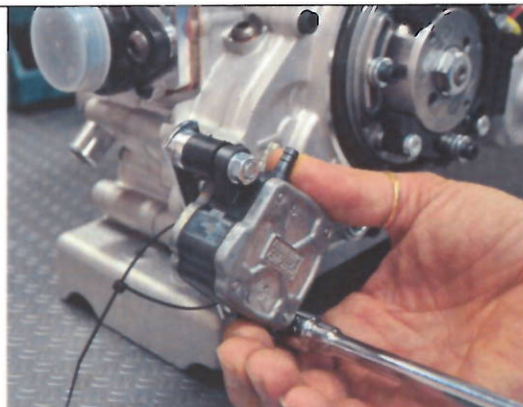

7



10mm Fixed Wrench

Assemble the two silent blocks on the coils support plate in the engine by inserting between the plate and the silent block the ground cable (yellow arrows). Place the coil support plate of the ignition coil in the two silent blocks, and insert the other end of the ground cables (blue arrows) and secure the coil by using the washers and 6 mm nuts supplied.

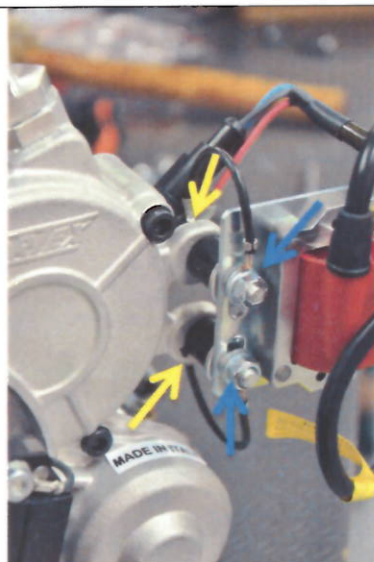

8

Connect the coil plug to the control unit connector plug (white arrow).





VORTEX FACTORY: Via E. Fermi, 5 - 27040 Campospinoso (PV)- ITALY - Tel. +39 0385 765200

9



Flat Plier

Remove the plastic cap from the head of the cylinder.



Spark Plug Wrench

Manually tighten the candle at the head of the cylinder.

Lock it with the key to loosening it then retighten 2/3 consecutive times; so as to allow the gasket to enter into seat properly. Now you can tighten the spark plug properly.

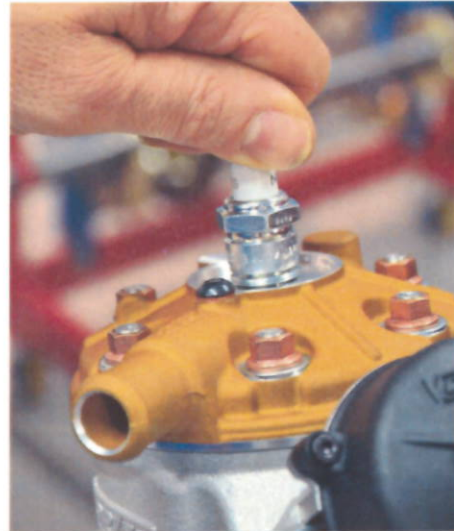

10

Insert the cable coil in the spark plug and tighten it.

For safety, we recommend you to secure the cable coil to the spark plug cap with a plastic strap.

Place the spark plug cap on the spark plug and press the cap fully.



11



Flat Plier

a. Remove the plastic cap from the intake manifold.

b. Remove the carburettor from the box.

c. Put the metal retaining clamp provided with the carburettor, outside the intake manifold.

d. Place the carburettor on the studs of the intake manifold.





VORTEX FACTORY: Via E. Fermi, 5 - 27040 Campospinoso (PV) - ITALY - Tel. +39 0385 765200

12



Flat Plier

Making sure that the carburettor is in the manifold in the correct position, secure it with the metal retaining clamp provided.



13

Remove the upper part of the carburettor unscrewing manually the lock ring.



14



8 mm Fixed Wrench

Secure the throttle cable screw on top of the carburettor cover.





VORTEX FACTORY: Via E. Fermi, 5 – 27040 Campospinoso (PV)- ITALY – Tel. +39 0385 765200

15

Plug the throttle cable inside the register and the carburettor cover making sure to leave the cable inside pawl.



16

Switch the throttle in the guillotine spring.



17

Pull the guillotine slide from the carburettor.



18

Place the pawl at the end of the throttle cable through the hole in the center of the guillotine slide. Lock the throttle in the guillotine slide by moving the cable to the side of the center.





VORTEX FACTORY: Via E. Fermi, 5 - 27040 Campospinoso (PV) - ITALY - Tel. +39 0385 765200

19

Place the guillotine slide and the spring in the carburettor.



20

Fix the upper cover of the carburettor to the carburettor itself, screwing manually the ring loosen as to previous picture **13**.



21



Plier

Using the pliers, very carefully, turn the two vents of the carburettor so that they are facing up.





VORTEX FACTORY: Via E. Fermi, 5 - 27040 Campospinoso (PV)- ITALY - Tel. +39 0385 765200

22

Place the vent pipe supplied in each of the two vents.
Cut half of the pipe in the center of the same, so as to create a vent hole.

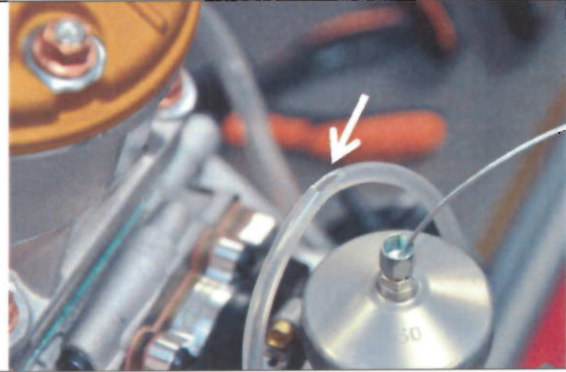

23



Flat Plier

a. Remove the plastic cap on the attack of the vacuum on the crankcase.

b. Place the fuel hose on the upper output of the pump and the other end on the attack on the crankcase vacuum.

Secure the fuel hose using plastic strap.



24

Insert the fuel hose in the output of the fuel pump.
Secure it with plastic straps.





VORTEX FACTORY: Via E. Fermi, 5 – 27040 Campospinoso (PV)- ITALY – Tel. +39 0385 765200

25

Insert the fuel hose from the pump to the carburettor inlet connection.
Secure the fuel hose with a plastic strap.



26

Place intake cylinders inside the intake silencer and mount the plastic protection grille on top of the intake cylinders.

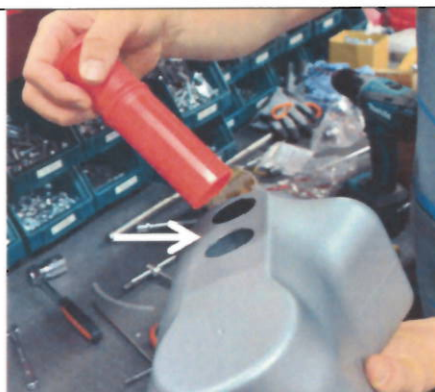

27

Place the rubber sleeve connector to the carburettor inside the intake muffler. To will find a groove in the sleeve, necessary to fix properly the sleeve to the plastic silencer.





VORTEX FACTORY: Via E. Fermi, 5 - 27040 Campospinoso (PV) - ITALY - Tel. +39 0385 765200

28

Check that the sleeve is fixed properly to the intake silencer. Incorrect installation may cause a loss of the intake silencer itself.



29



Flat Plier

Fasten the intake silencer previously assembled to the carburettor by using the specific metal clamp supplied.

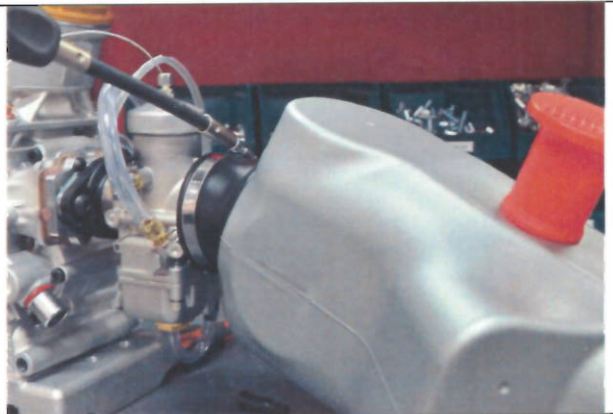

30



3 mm and 5 mm Allen T-Wrench Tools

- a. Attach the red wire to the starter using the screw supplied.
- b. Unscrew the 5 mm screw. Place the terminal of the ground wire (black wire) inside the screw and fasten it.





VORTEX FACTORY: Via E. Fermi, 5 - 27040 Campospinoso (PV)- ITALY - Tel. +39 0385 765200

31

Cover the cable clamps with rubber caps inserted in the same cables.



32

Your Vortex engine is now ready to be installed on the chassis.



VORTEX FACTORY: Via E. Fermi, 5 – 27040 Campospinoso (PV)– ITALY – Tel. +39 0385 765200

3. ASSEMBLY ENGINE/CHASSIS

1



T 5 Allen T-Wrench 10 mm Fixed Wrench

Put the sprocket on the sprocket hub and secure it with 6 screws, 12 washers and 6 nuts of 6 mm.

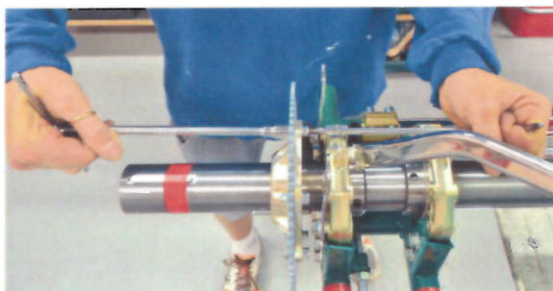

2



8mm Allen T-Wrench

Now place the engine on the chassis. Slightly tighten the screws to the engine in order to keep the engine in the same location. Do not fully tighten the screws.

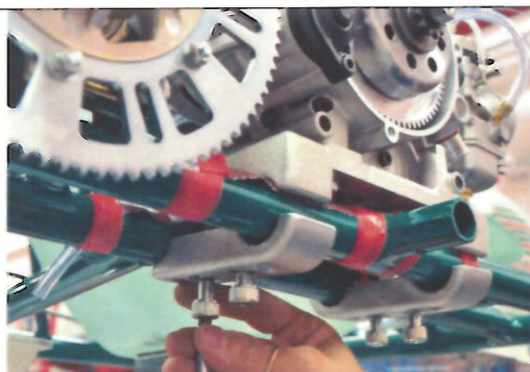

3



Flat bar

Align the sprocket fixed to the sprocket hub with the pinion on the clutch bell. Now install the appropriate chain length. The chain length varies according to the ratio used.





VORTEX FACTORY: Via E. Fermi, 5 - 27040 Campospino (PV) - ITALY - Tel. +39 0385 765200

4

To adjust the chain tension, move the engine trying to get the correct tension.
The correct tension of the chain is obtained when it has a "free" movement in up and down by about 1 cm.

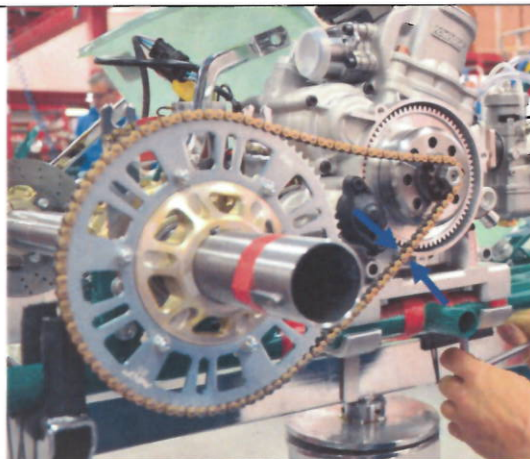

5



17 mm Fixed Wrench

When the chain tension is correct, tighten the screws completely and recheck the chain tension. Lay now the adjusting screw (if provided by the manufacturer of the chassis) to the engine plate and secure it.

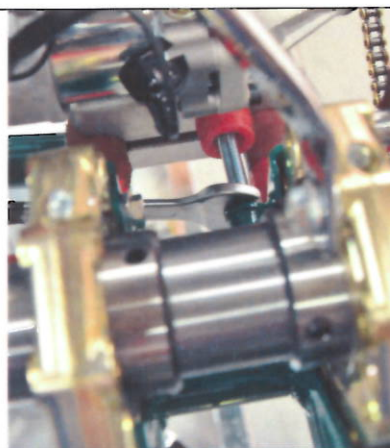

6

Now insert the throttle cable into the sheath.

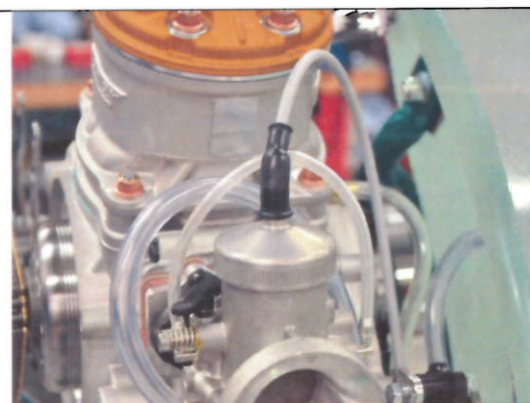



VORTEX FACTORY: Via E. Fermi, 5 - 27040 Campospinoso (PV)- ITALY - Tel. +39 0385 765200

7

Place the free part of the gas throttle in fixed registry on the main tube of the chassis.



8



3 mm Allen T-Wrench

Place the clamp on the gas throttle and put the free end in the pedal mounting. Now go through the same end within the clamp and tighten accurately. The clamp is supplied with the engine kit.



9



Flat Plier

Remove the carburettor intake silencer unscrewing the metal clamp.



10



8 mm Allen T-Wrench

Adjust the stop of the gas pedal by the screw stopper on the frame; so that the pedal stops before the guillotine slide of the carburettor is fully open at the end of the stroke.





VORTEX FACTORY: Via E. Fermi, 5 - 27040 Campospinoso (PV)- ITALY - Tel. +39 0385 765200

11

Place the fuel hose from the tank at the entrance of the fuel pump.

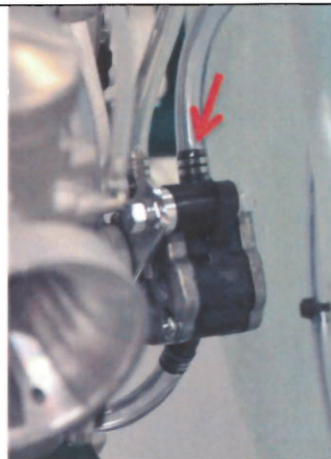

12



5 mm Allen T-Wrench

Now mount the battery holder on the chassis at the side of the seat using the plastic (upper) and iron (lower) jumpers supplied. A mounting spacer between the jumpers and battery holder may be necessary to overcome the brake hose.

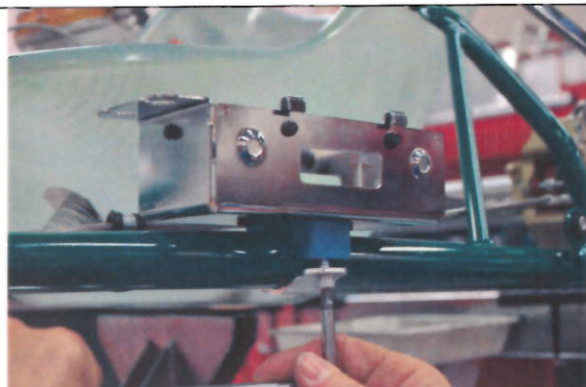

13



4 mm Allen T-Wrench
10 mm Fixed Wrench

Remove the relay from its housing in the wiring. Fix the housing of the relay to the battery holder using the 6x25 mm screw, the double cone washer, the two rubber spacers, the washer and the 6 mm nut.

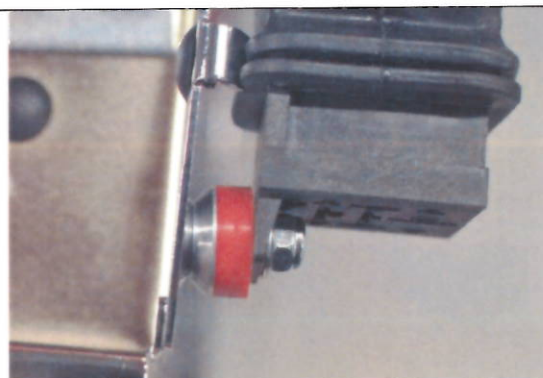



VORTEX FACTORY: Via E. Fermi, 5 - 27040 Campospinoso (PV)- ITALY - Tel. +39 0385 765200

14

Manually place the relay into the wiring. Do not use any tools to do this.



15



14 mm Fixed Wrench

Place the start button (green) and the stop button (red) in the two slots in the front of the battery holder. Secure them by tightening the nuts already placed on the wiring cable.

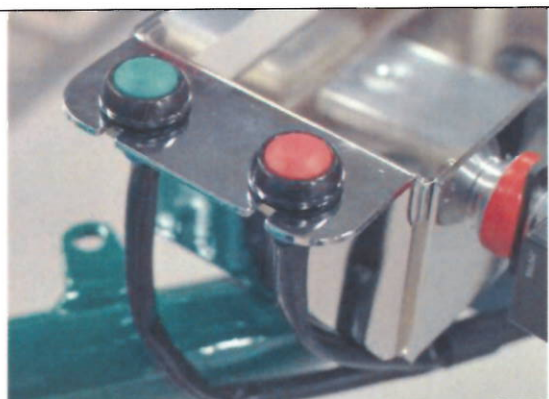

16

Place the battery inside the battery holder itself. Insert the wiring cables in the battery plugs. The red cable into the red plug and the black wire into the black plug. Secure the battery to its holder using the two rubber O-rings supplied.



17

Secure the relay with the specific spring provided. Make sure that the spring is in the correct position and press. If it is necessary, bend slightly the spring end with a calliper so as to ensure proper fastening.

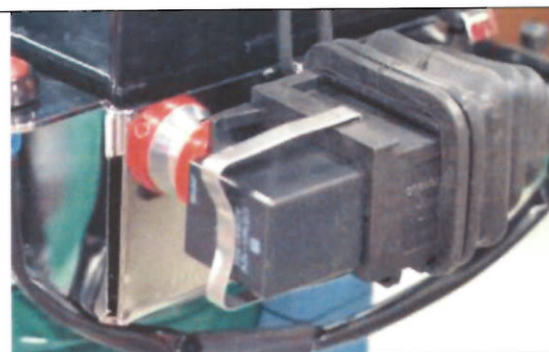



VORTEX FACTORY: Via E. Fermi, 5 – 27040 Campospinoso (PV)– ITALY – Tel. +39 0385 765200

18

Pass the main cable to the side of the seat and secure it to the frame using the plastic straps. **Make sure there are no loose cables, they could touch the asphalt and become damaged beyond repair.**

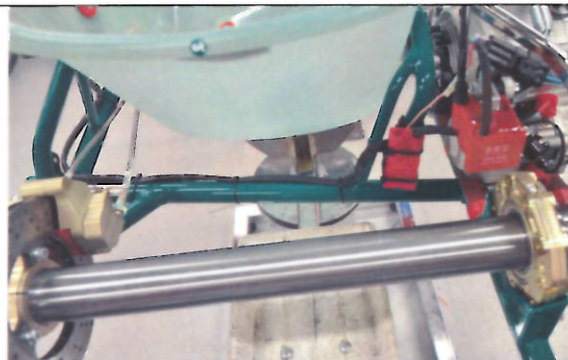

19

Insert the plug that you find at the end of the cable from the battery with the other plug of the cable already placed on the engine.



20



4 mm Allen T-Wrench
10 mm Fixed Wrench
6 mm Allen T-Wrench

Mount the radiator and secure it with the appropriate housing welded to the frame (yellow arrows)



21



Flat Plier

Using the metal clamps provided, fasten the cooling tubes to the radiator.





VORTEX FACTORY: Via E. Fermi, 5 - 27040 Campospino (PV)- ITALY - Tel. +39 0385 765200

22



Flat Plier
Pipe Cutter

Cut the upper tube and secure the thermostatic valve using the special metal clamps.



23



Flat Plier

Now, using the smallest metal clamps provided, fasten the bypass pipe to the thermostatic valve.



24



Pipe Cutter

Taking care to properly align the thermostatic valve with the T-fitting, cut the lower cooling tube, place the metal clamp, and then connect the hose to the tee-connector





VORTEX FACTORY: Via E. Fermi, 5 - 27040 Campospinoso (PV)- ITALY - Tel. +39 0385 765200

25



Flat Plier

Secure the tee-connector and bypass pipe by tightening with the special metal clamps.



26



Flat Plier

Place the cooling pipes in the engine and using the metal clamps provided, make sure the bypass pipe is connected to the thermostatic valve.

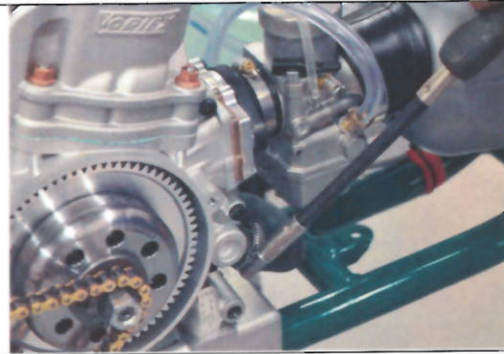

27



Flat Plier

Connect the cooling tubes to the thermostatic valve and to the tee-connector and using the metal clamps provided, firmly secure them.

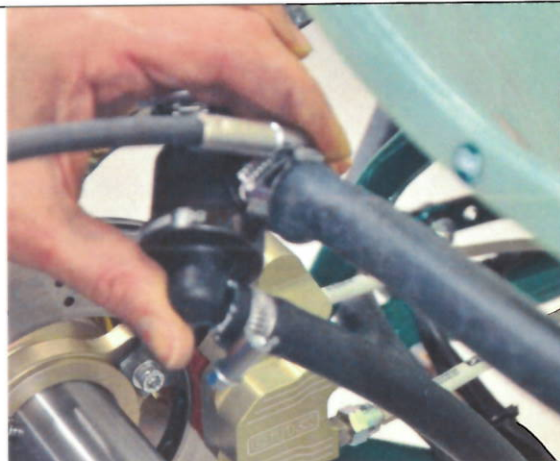



VORTEX FACTORY: Via E. Fermi, 5 - 27040 Campospinoso (PV) - ITALY - Tel. +39 0385 765200

28

For proper operation of the cooling system it is necessary to bleed the system of any air bubbles.

To adequately perform the purge operation proceed as follows:

Fill the radiator with water and raising the kart from the radiator side, scrape out the excess air. Now top up with more water. Do not close the radiator cap.



29



4 mm Allen T-Wrench

Loosen the screw of the crankcase (red arrow) and keep it open until only water comes out. Now tighten the screw and top up the radiator with water.



30



4 mm Allen T-Wrench

Now proceed with the purging of the cylinder head circuit. Loosen the screw on the cylinder head (yellow arrow) and keep it open until only water comes out. Now tighten the screw and top up the radiator with water. At this point you can close the radiator cap.

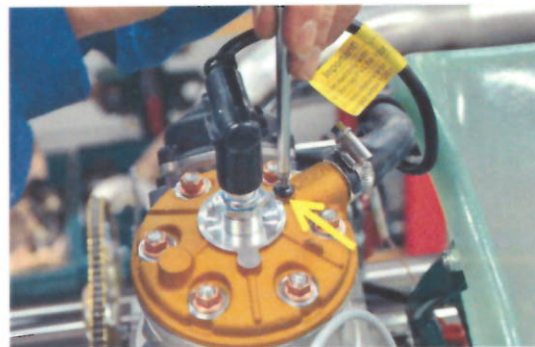

31

Insert the hooks of the two springs in the special holes on the exhaust manifold.





VORTEX FACTORY: Via E. Fermi, 5 - 27040 Campospinoso (PV) - ITALY - Tel. +39 0385 765200

32



Hook

Place the exhaust system on the manifold.
Fasten the exhaust silencer by inserting the hooks of the springs inside the special holes on the exhaust.



33



Hook

Place the exhaust system inside the support
already mounted on the chassis and secure it
using the two springs provided.

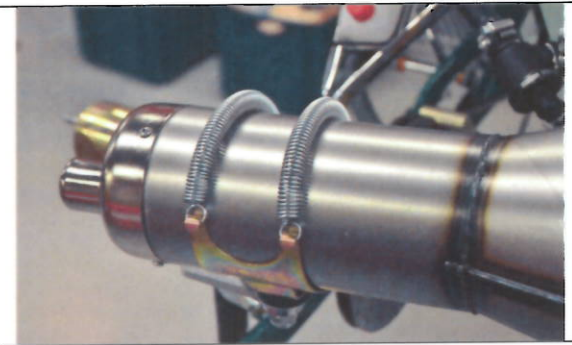



VORTEX FACTORY: Via E. Fermi, 5 – 27040 Campospino (PV) – ITALY – Tel. +39 0385 765200

4. STARTING AND BRAKE-IN



Only a proper break-in will insure the best performance out of your engine in the future and guarantee its long and trouble-free life.

Break-in is required when an engine is new or has undergone a major service of the engine's main parts (piston, cylinder, connecting rod, etc.).

1 Prepare fuel. Vortex engine works with commercial gasoline, leaded or unleaded, as well as racing fuel, with minimum 95 ROM.
Mix Oil and gasoline at 4% (i.e. 40cc of oil every 1.000cc of fuel).

2 Use a high-quality synthetic oil specifically made for kart engines. Vortex suggests Petronas Rok Lube, however other brands with the same composition might be suitable.
Check any requirements of your ASN regarding the use of specific brand/type.

3 Shake the can thoroughly to mix the fuel and the oil properly. Then fill the gas tank in your kart.
A mistake in measurements could result in engine damage.

4 Buttons operation: to start the engine, press the green button. To stop the engine press the red button.

5 To start a cold engine raise the starter lever positioned on the carburettor.

6 Press the start (green) button so as to enable the fuel pump to pump the fuel in the carburettor.

7 Once the engine starts down the starter lever.

8 Warm up the engine accelerating driving up the motor speed and then let it down again alternately. Bring the water temperature around 48 -50 ° C before stopping the engine. **Do not accelerate** fully but only partially.
Check that the cooling system warms up evenly, in case it warms unevenly proceed again with the bleeding of the cooling system as described in paragraphs 28-29-30.

9 Once the engine is warmed up and the cooling system works properly, proceed to the track. Gently accelerating, the clutch will begin to engage and your kart will start moving.

10 Run the engine by alternating a few seconds on and off the throttle at $\frac{3}{4}$ of the opening.
Do not hold the throttle at a constant speed.
Continue this way for 5/6 laps.

11 Check everything on the kart is tighten properly. Be careful, engine and muffler are hot.



VORTEX FACTORY: Via E. Fermi, 5 - 27040 Campospinoso (PV) - ITALY - Tel. +39 0385 765200

12 Return to the track and slowly increase the RPM and duration of the acceleration phase for 10/15min more. Intermittently open the throttle fully and then release it.

13 After 10/15 minutes of brake-in, your engine is ready for competition. During the break-in, nuts and bolts tend to loosen. Once the engine is cold, check the torque of the exhaust, head, etc.



VORTEX FACTORY: Via E. Fermi, 5 – 27040 Campospinoso (PV)- ITALY – Tel. +39 0385 765200

5. SERVICING YOUR ENGINE



Good maintenance is essential for safe, economical and trouble-free operation. Here you will find a maintenance schedule for your engine. Routine inspection procedures are very simple by using basic tools. Some service tasks that are more difficult or needs special tools must be performed by Vortex technicians or qualified mechanics.

Timing schedule periods are only indicative.

5.1. Maintenance Schedule Guide and Adjustments

Carburettor	Cleaning	Every race/test session
Throttle Cable	Check	Every race
Spark Plug	Check Change	Every race After 30 hours
Exhaust	Internal Cleaning	Up to 10 hours
Clutch	Check and Cleaning Change	Up to 10 hours After 30 hours
Piston	Change	After 30 hours
Chain	Change	After 20 hours
Cylinder	Honing	After 30 hours
Connecting Rod	Change	After 90 hours
Bottom End Bearings	Change	After 90 hours

5.2. Torque Chart

Cylinder head \varnothing 8 mm Nut	kgm 1,8
Exhaust manifold \varnothing 7 mm Nut	kgm 1,5
Crankcase \varnothing 6 mm Screws	kgm 1,2
Bendix Cover	kgm 0,8
Ignition Nut	kgm 6 (Use threadlocker)
Pinion	kgm 5 (Use threadlocker)
Ignition Rotor Nut	kgm 2,8
Bell-shaped Nut Pinion	kgm 2,8
Ignition \varnothing 5 Screws	kgm 0,8
Nylon crankshaft stuffer	kgm 0,8 (Use threadlocker)



VORTEX FACTORY: Via E. Fermi, 5 - 27040 Campospinoso (PV)- ITALY - Tel. +39 0385 765200

5.3. Sizes and Measures

Cylinder/Piston Tolerance	11,0
Timing GP	3mm
Piston Size	
W10125/ROK	53,95
W10122/ROK	54,00
W10126/ROK	54,05
W10124/ROK	54,10
W10127/ROK	54,15

5.4. Chain

	<p>Lube the chain every race by spraying chain lube on the chain while manually rotating the rear wheel. To replace the chain, loosen the engine and slide it back to release the old chain from the sprocket. Reverse the procedure after installing a new chain.</p>
--	--

5.5 Throttle Cable

	<p>Lubricate the throttle cable each time the engine is run. Also check, and adjust the cable as needed, to assure the correct throttle and that the throttle returns properly and opens full size. If the cable frays, it must be replaced.</p>
--	--



VORTEX FACTORY: Via E. Fermi, 5 - 27040 Campospinoso (PV) - ITALY - Tel. +39 0385 765200

5.6. Carburettor

Cleaning:

Fuel and oil may contain impurities, and/or residues.

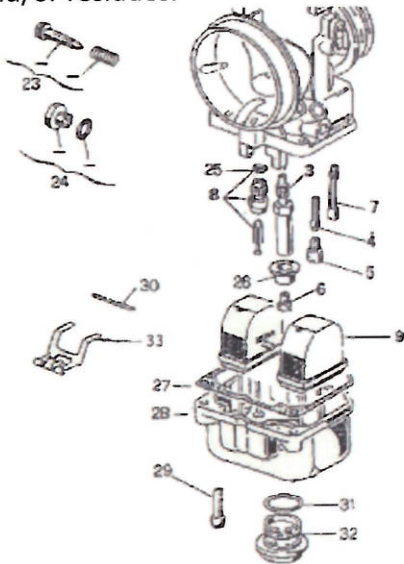

1. Take the intake silencer off the carburettor by unscrewing the clamp.
2. Disconnect the throttle cable from the carburettor.
3. Take the carburettor off the engine and open the float chamber (28) by unscrewing the three screws (29). Clean the parts, openings and passages with compressed air. Check the float chamber gaskets and eventually change them if damaged.
4. Close the float chamber by screwing the three screws (29) and replace the carburettor in the engine.
5. Clean the inside of the intake silencer.
6. Attach the intake silencer assembly to the adaptor.
7. Tighten it with the specific clamp. Wrong assembly will cause the loss of the intake silencer.

Sostituzione Getto del massimo:

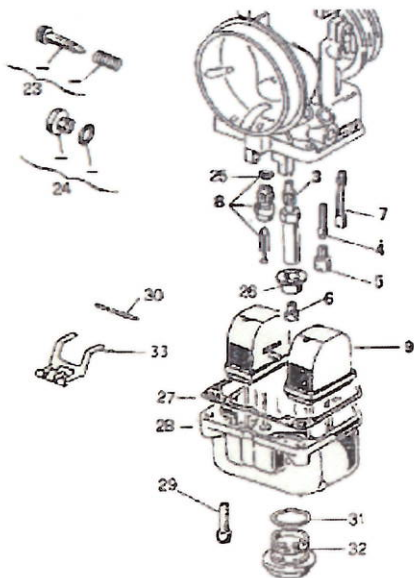

1. Take the intake silencer off the carburettor by unscrewing the clamp.
2. Disconnect the throttle cable from the carburettor together with the spring and the guillotine slide.
3. Take the carburettor off the engine and open the floating chamber (28) by unscrewing the special cap (32) in the middle of the chamber. Clean the parts, openings and passages with compressed air.
4. Unscrew the main jet (6) by means of a flat plier. Replace it with another calibrated differently. Be careful, the washer (26) must be installed in one position only. A wrong assembly may cause the carburettor complete malfunction.
5. Check the plug gasket (31) of the floating chamber is still intact and if damaged, replace it.
6. Close the floating chamber by securing the special cap (32) and mount the carburettor on the engine.
7. Clean the inside of the intake silencer.
8. Mount the intake silencer on the carburettor flange.
9. Tighten it with the specific clamp. Wrong assembly will cause the loss of the intake silencer.



VORTEX FACTORY: Via E. Fermi, 5 - 27040 Campospinoso (PV) - ITALY - Tel. +39 0385 765200

5.7. Spark Plug

<p>Cleaning: Oils produce carbon deposits or residues that make necessary the spark plug to be checked and cleaned, at least every 5 hours.</p>	<p>Unplug the spark plug and clean it by using a brass metal brush.</p>
<p>Setting Plug Gap:</p>	<p>Use a specific spark plug gap gauge to set up correct gap. Correct gap: 0,8 mm.</p>

5.8. Exhaust

<p>Cleaning: Oils produce carbon deposits or residues that make necessary the exhaust to be checked and cleaned, at least every 10 hours.</p>	<ol style="list-style-type: none"> 1. Remove the muffler from the engine by removing the two springs in the cradle between exhaust and manifold. 2. Unscrew the 3 bolts in the exhaust end cap. 3. Warm up the pipe with a heat source and remove any carbon deposits by means of a metal brush.
--	---

5.9. Clutch and ignition sprocket

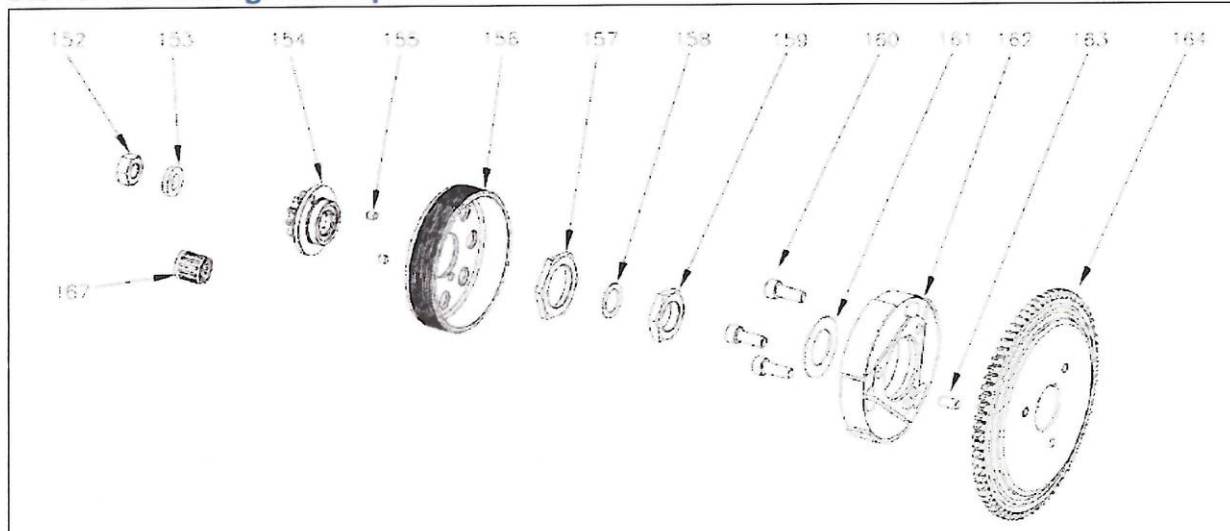

<p>Cleaning/Replacement sprocket:</p>	<ol style="list-style-type: none"> 1. Take the Bendix cover away. 2. Block the clutch drum by means of the specific Vortex tool. 3. Loosen anticlockwise the clutch bell nut (152). Remove the connecting rod (153), the clutch bell (156) and the roller bearing (167). 4. Unscrew the three 6x14mm screws (160) of the clutch. 5. Unscrew the central nut clockwise (159) by
--	---



VORTEX FACTORY: Via E. Fermi, 5 - 27040 Campospinoso (PV) - ITALY - Tel. +39 0385 765200

	<p>means of a 24mm fixed wrench and remove it. Block the ignition sprocket by the special Vortex tool.</p> <p>6. Remove the clutch (162) with the appropriate extractor.</p> <p>7. Before installing a new clutch we suggest you to clean the area and the clutch bell with a solvent.</p> <p>ASSEMBLY</p> <p>8. Mount the new clutch (162) on the ignition sprocket pressing with the fingers and secure it with the three 6x14mm screws (160). Use threadlockers for better locking.</p> <p>9. Re-position the elastic sprocket (161) and the central nut (159) and secure them. Use threadlockers for better locking.</p> <p>10. After securing the central nut insert the sprocket (158).</p> <p>11. Lubricate the roller bearing (167) and mount it into the crankshaft.</p> <p>12. Install the clutch bell (156), the washer (153) and secure the nut (152). Use threadlockers for better locking.</p> <p>13. Mount the Bendix cover.</p>
<p>Ignition Sprocket Replacement</p>	<p>1. Take the Bendix cover away.</p> <p>2. Block the clutch drum by means of the specific Vortex tool.</p> <p>3. Loosen anticlockwise the clutch bell nut (152). Remove the connecting rod (153), the clutch bell (156) and the roller bearing (167).</p> <p>4. Unscrew the three 6x14mm screws (160) of the clutch.</p> <p>5. Unscrew the central nut clockwise (159) by means of a 24mm fixed wrench and remove it. Block the ignition sprocket by the special Vortex tool.</p> <p>6. Remove the clutch (162) and the ignition sprocket (164) with the appropriate extractor.</p> <p>7. Unscrew the three 6x14mm screws (160) of the clutch.</p> <p>8. Before installing a new clutch we suggest you to clean the area and the clutch bell with a solvent.</p> <p>ASSEMBLY</p>



VORTEX FACTORY: Via E. Fermi, 5 – 27040 Campospinoso (PV)– ITALY – Tel. +39 0385 765200

	<p>9. Mount the clutch (162) on the new ignition sprocket (164) with the three 6x14mm screws (160). Use threadlockers for better locking.</p> <p>10. Mount the ignition sprocket on the crankshaft slightly pressing with the fingers.</p> <p>11. Re-position the elastic sprocket (161) and the central nut (159) and secure them. Use threadlockers for better locking.</p> <p>12. After securing the central nut insert the sprocket (158).</p> <p>13 Lubricate the roller bearing (167) and mount it into the crankshaft.</p> <p>14. Install the clutch bell (156), the washer (153) and secure the nut (152). Use threadlockers for better locking.</p> <p>13. Mount the Bendix cover.</p>
--	---

5.10. Pinion

<p>Some ASNs admit the use of pinions Z11, Z12 or Z13. Vortex standard supply includes the pinion Z12.</p>	<ol style="list-style-type: none">1. Block the clutch drum by means of the specific Vortex tool.2. Loosen anticlockwise the clutch bell nut (152). Remove the connecting rod (153), the clutch bell (156) and the roller bearing (167).3. Unscrew the nut (157) located in the clutch drum.4. Install the new pinion in the clutch drum and secure it with the central nut (157). Use threadlockers for better locking. <p>If you want to install the pinion Z11 you will need an appropriate spacer.</p> <ol style="list-style-type: none">5. Lubricate the roller bearing (167) and mount it into the crankshaft.6. Install the clutch bell (156), the washer (153) and secure the nut (152). Use threadlockers for better locking.
--	---

5.11. Cylinder Head

<p>Oils produce carbon deposits or residues that make necessary the cylinder head to be checked and cleaned, at least every race.</p> <p>Be aware, cylinder head volume may be changed after the race, carbon deposits may cause</p>	<p>In order to perform this job, we highly recommend taking the engine off the chassis. However, you may do the job even with the engine mounted.</p> <ol style="list-style-type: none">1. Unscrew the spark plug (3).2. Unscrew the 6 nuts on top of the head (12) and the 6 washers (13).
---	---



VORTEX FACTORY: Via E. Fermi, 5 - 27040 Campospinoso (PV)- ITALY - Tel. +39 0385 765200

variations on the cylinder head volume.

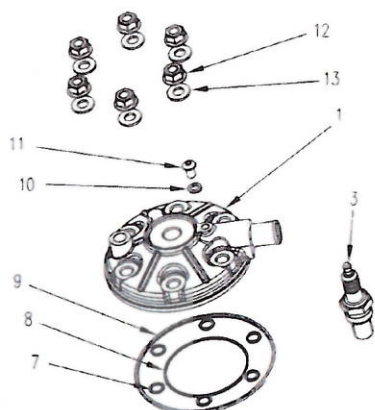

3. Remove the head by pulling it up carefully.
4. Clean the combustion chamber using a rag moistened with gasoline or solvent.

ASSEMBLY

5. Check the copper gasket of the cylinder. If damaged or mounted wrongly, can affect the volume of the chamber.
6. Re-place cylinder head carefully in the 4 studbolts and check that o-rings (7-8-9) are properly fitted in place.
- 7 Insert brass washers (13) and manually screw nuts (12).
8. Tighten cylinder head nuts with the proper tool and torque, respecting the tightening torque.

5.12. Cylinder

Every 30 hours cylinder must be honed.

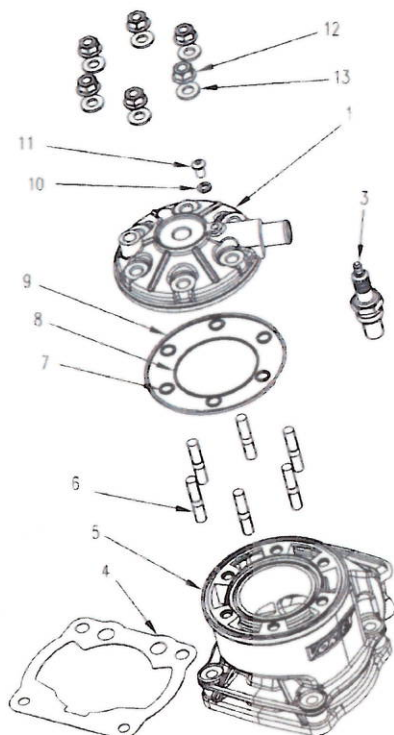

In order to perform this job, we highly recommend taking the engine off the chassis. However, you may do the job even with the engine mounted.

1. Take away the muffler from the engine by removing the springs fixing it to the exhaust manifold.
2. Unscrew and remove the spark plug (3).
3. Unscrew and remove the 6 nuts on top of head (12) and the 6 washers (13).
4. Remove the head by pulling it up carefully.
5. Remove the cylinder with one hand by pulling it up. To avoid contact with the crankcase, use the other hand to hold the connecting rod.

Whenever you disassemble the cylinder, we recommend replacing the cylinder gasket (4).

ASSEMBLY

Check the tolerance between piston and cylinder. Wrong tolerance may cause serious damage.

6. Place a new gasket (4) into the four studbolts.
7. Insert cylinder into the four studs.
8. Check the rubber o-ring (7-8-9) and eventually replace them with new ones. If damaged or mounted wrongly, can affect the volume of the chamber.
9. Re-place the cylinder head carefully in the 4 studbolts (6).



VORTEX FACTORY: Via E. Fermi, 5 – 27040 Campospinoso (PV)- ITALY – Tel. +39 0385 765200

	<p>10. Insert brass washers (13) and manually screw the nuts (12).</p> <p>11. Tighten cylinder head with the proper tool and torque.</p> <p>Important: After honing the cylinder and eventually changing the piston, the engine must go through another break-in period. See "Starting and Break-in".</p>
--	---

5.13. Piston

Oils produce carbon deposits or residues that make necessary the spark plug to be checked and cleaned, at least every race.

Be aware, cylinder head volume may be changed after the race, carbon deposits may cause variations on the cylinder head volume.

Every 30 hours piston must be replaced.

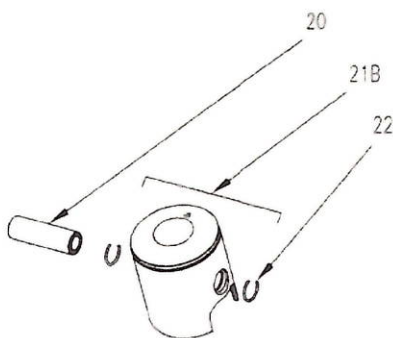

In order to perform this job, we highly recommend taking the engine off the chassis. However, you may do the job even with the engine mounted.

1. Take away the muffler from the engine by removing the 2 springs fixing it to the exhaust manifold.
2. . Unscrew and remove the spark plug (3).
3. Unscrew and remove the 6 nuts on top of head (12) and the 6 washers (13).
4. Remove the head by pulling it up carefully.
5. Remove the cylinder with one hand by pulling it up. To avoid contact with the crankcase, use the other hand to hold the connecting rod.

Whenever you disassemble the cylinder, we recommend replacing the cylinder gasket (4).

6. Remove the 2 piston pin circlips (22) by squeezing the ends together with the needle-nose.
7. Hook the connecting rod each side with two fingers.
8. Push the piston pin (20) off the piston by using a proper tool.
9. In order to avoid damages pull the piston up with one hand while holding the connecting rod with the other.
10. Take the roller bearing off the connecting rod

ASSEMBLING

Check the tolerance between piston and cylinder. Wrong tolerance may cause serious damage.

11. Lubricate and replace a new roller bearing, if needed, on the connecting rod.
12. Insert a new piston in the connecting rod. The arrow marked on top of it, must face the exhaust port.
13. Insert the piston pin into the piston.



VORTEX FACTORY: Via E. Fermi, 5 – 27040 Campospinoso (PV)– ITALY – Tel. +39 0385 765200

	<p>14. Insert piston pin circlips on each side of the piston. Be aware, wrong assembly of piston pin circlips may cause important damage.</p> <p>15. Fit the piston ring and check both ends close properly against the brass pin inserted in the piston.</p> <p>16. Place a new gasket (4) into the 4 studbolts.</p> <p>17. Insert the cylinder into the 4 studbolts carefully.</p> <p>18. Check the rubber O-rings (7-8-9) and the copper gasket and eventually replace them with new ones. If damaged or mounted wrongly, can affect the volume of the chamber.</p> <p>19. Re-place the cylinder head carefully in the 4 studbolts (6).</p> <p>20. Insert brass washers (13) and nuts manually (12).</p> <p>21. Tighten cylinder head with proper tool and torque.</p> <p>Important: After changing the piston, the engine must go through another break-in period. See "Starting and Break-in".</p>
--	--

5.14. Connecting Rod

Every 60 hours the con-rod and roller cage must be changed. During this operation please check and replace the connecting rod, too, if damaged.

Due to special tools required, this operation must be performed by the Vortex technicians or qualified mechanics only.

5.15. Bottom End bearings

Bearings must be checked and eventually replaced, after 60 hours of use.

Bearings must be assembled or reassembled, with name and type facing each others.

Due to special tools required, this operation must be performed by the Vortex technicians or qualified mechanics only.



VORTEX FACTORY: Via E. Fermi, 5 - 27040 Campospinoso (PV)- ITALY - Tel. +39 0385 765200

7. CONTACTS

MANUFACTURER

Vortex Factory

Via E. Fermi 5

27040 – Campospinoso

Italy

Tel: +39 0385 765200

support@vortex-engines.com